

Low Dropout, Two-Bank LED Driver with PWM Brightness Control

FEATURES

- Regulated Output Current with 2% LED-to-LED Matching
- Drives Up to Four LEDs at 25mA Each in a Common Cathode Topology
- 28mV Typical Dropout Voltage Extends Usable Supply Range in Li-Ion Battery Applications
- Brightness Control Using PWM Signals
- Two 2-LED Banks with Independent Enable and PWM Brightness Control per Bank
- No Internal Switching Signals—Eliminates EMI
- Default LED Current Eliminates External Components
 - Default values from 3mA to 10mA (in 1mA increments) available using innovative factory EEPROM programming
 - Optional external resistor can be used for high-accuracy, user-programmable current
- Over-Current and Over-Temperature Protection
- Available in Wafer Chip-Scale Package or 2,5mm × 2,5mm SON-10

APPLICATIONS

- Keypad and Display Backlighting
- White and Color LEDs
- Cellular Handsets
- PDAs and Smartphones

DESCRIPTION

The TPS7510x linear low dropout (LDO) matching LED current source is optimized for low power keypad and navigation pad LED backlighting applications. The device provides a constant current to up to four unmatched LEDs organized in two banks of two LEDs each in a common-cathode topology. Without an external resistor, the current source defaults to factory-programmable, preset current level with $\pm 0.5\%$ accuracy (typical). An optional external resistor can be used to set initial brightness to user-programmable values with higher accuracy. Brightness can be varied from off to full brightness by inputting a pulse width modulation (PWM) signal on each Enable pin. Each bank has independent enable and brightness control, but current matching is done to all four channels concurrently. The input supply range is ideally suited for single-cell Li-Ion battery supplies and the TPS7510x can provide up to 25mA per LED.

No internal switching signals are used, eliminating troublesome electromagnetic interference (EMI). The TPS7510x is offered in an ultra-small, 9-ball, 0.4mm ball-pitch wafer chip-scale package (WCSP) and a 2,5mm × 2,5mm, 10-pin SON package, yielding a very compact total solution size ideal for mobile handsets and portable backlighting applications. The device is fully specified over $T_J = -40^\circ\text{C}$ to $+85^\circ\text{C}$.

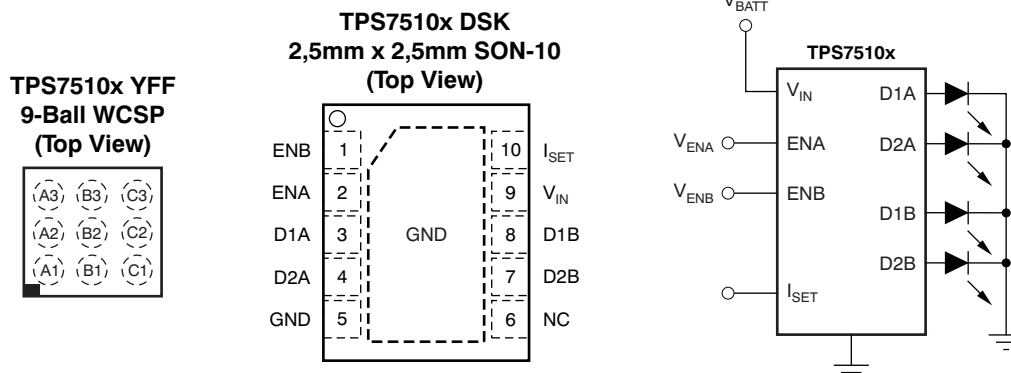

Please be aware that an important notice concerning availability, standard warranty, and use in critical applications of Texas Instruments semiconductor products and disclaimers thereto appears at the end of this data sheet.

All trademarks are the property of their respective owners.



This integrated circuit can be damaged by ESD. Texas Instruments recommends that all integrated circuits be handled with appropriate precautions. Failure to observe proper handling and installation procedures can cause damage.

ESD damage can range from subtle performance degradation to complete device failure. Precision integrated circuits may be more susceptible to damage because very small parametric changes could cause the device not to meet its published specifications.

ORDERING INFORMATION⁽¹⁾

PRODUCT ID	OPTIONS ⁽²⁾
TPS7510x <i>yyyz</i>	X is the nominal default diode output current (for example, 3 = 3mA, 5 = 5mA, and 0 = 10mA). YYY is the package designator. Z is the reel quantity (R = 3000, T = 250).

- (1) For the most current package and ordering information see the Package Option Addendum at the end of this document, or see the TI web site at www.ti.com.
- (2) Default set currents from 3mA to 10mA in 1mA increments are available through the use of innovative factory EEPROM programming. Minimum order quantities may apply. Contact factory for details and availability.

ABSOLUTE MAXIMUM RATINGS⁽¹⁾

Over operating temperature range (unless otherwise noted).

PARAMETER	VALUE
V _{IN} range	-0.3V to +7.0V
V _{ISET} , V _{ENA} , V _{ENB} , V _{DX} range	-0.3V to V _{IN}
I _{DX} for D1A, D2A, D1B, D2B	35mA
D1A, D2A, D1B, D2B short circuit duration	Indefinite
Continuous total power dissipation	Internally limited
Junction temperature (T _J)	-55°C to +150°C
Storage temperature	-55°C to +150°C

- (1) Stresses above these ratings may cause permanent damage. Exposure to absolute maximum conditions for extended periods may degrade device reliability. These are stress ratings only, and functional operation of the device at these or any other conditions beyond those specified is not implied.

DISSIPATION RATINGS

BOARD	PACKAGE	R _{θJC}	R _{θJA}	DERATING FACTOR ABOVE			
				T _A = +25°C	T _A < +25°C	T _A = +70°C	T _A = +85°C
Low-K ⁽¹⁾	YFF	55°C/W	208°C/W	4.8mW/°C	480mW	264mW	192mW
	High-K ⁽²⁾	YFF	142°C/W	7.0mW/°C	704mW	387mW	282mW
	DSK	40°C/W	60.6°C/W	17mW/°C	1650mW	908mW	660mW

- (1) The JEDEC low-K (1s) board used to derive this data was a 3 inch x 3 inch, two-layer board with 2 ounce copper traces on top of the board.
- (2) The JEDEC high-K (2s2p) board used to derive this data was a 3 inch x 3 inch, multi-layer board with 1 ounce internal power and ground planes and 2 ounce copper traces on top and bottom of the board.

RECOMMENDED OPERATING CONDITIONS

PARAMETER		MIN	TYP	MAX	UNIT
V _{IN}	Input voltage	2.7		5.5	V
I _{DX}	Operating current per LED	3		25	mA
t _{PWM}	On-time for PWM signal	33			μs
T _J	Operating junction temperature range	-40		+85	°C

ELECTRICAL CHARACTERISTICS

Over operating junction temperature range ($T_J = -40^\circ\text{C}$ to $+85^\circ\text{C}$), $V_{IN} = 3.8\text{V}$, I_{DX} and $I_{DX} = 3.3\text{V}$, $R_{SET} = 32.4\text{k}\Omega$, and EN_A and $EN_B = 3.8\text{V}$, unless otherwise noted. Typical values are at $T_A = +25^\circ\text{C}$.

PARAMETER		TEST CONDITIONS		MIN	TYP	MAX	UNIT
I_{SHDN}	Shutdown supply current	$V_{EN_A,B} = 0\text{V}$, $V_{DX} = 0\text{V}$			0.03	1.0	μA
I_{GND}	Ground current	$I_{SET} = \text{open}$, $V_{IN} = 4.5\text{V}$ YFF package			170	200	μA
		$I_{DX} = 5\text{mA}$, $V_{IN} = 3.8\text{V}$ DSK package			170	230	μA
ΔI_D	Current matching ($I_{DXMAX} - I_{DXMIN}/I_{DXMAX}$) $\times 100\%$	$T_A = +25^\circ\text{C}$		0	2	4	%
		$T_A = -40^\circ\text{C}$ to $+85^\circ\text{C}$	YFF package	0		5	%
			DSK package	0		6	%
$\Delta I_{DX}\%/\Delta V_{IN}$	Line regulation	$3.5\text{V} \leq V_{IN} \leq 4.5\text{V}$, $I_{DX} = 5\text{mA}$			2.0		%/V
$\Delta I_{DX}\%/\Delta V_{DX}$	Load regulation	$1.8\text{V} \leq V_{DX} \leq 3.5\text{V}$, $I_{DX} = 5\text{mA}$			0.8		%/V
V_{DO}	Dropout voltage of any DX current source (V_{DX} at $I_{DX} = 0.8 \times I_{DX, nom}$)	$I_{DXnom} = 5\text{mA}$			28	100	mV
		$I_{DXnom} = 15\text{mA}$			70		
V_{ISET}	Reference voltage for current set			1.183	1.225	1.257	V
I_{OPEN}	Diode current accuracy ⁽¹⁾	$I_{SET} = \text{open}$, $V_{DX} = V_{IN} - 0.2\text{V}$	YFF package		0.5	3	%
			DSK package		0.5	4	%
I_{SET}	I_{SET} pin current range			2.5		62.5	μA
k	I_{SET} to I_{DX} current ratio ⁽¹⁾				420		
V_{IH}	Enable high level input voltage			1.2			V
V_{IL}	Enable low level input voltage					0.4	V
I_{INA}	Enable pin A (V_{EN_A}) input current	$V_{EN_A} = 3.8\text{V}$			5.0	6.1	μA
		$V_{EN_A} = 1.8\text{V}$			2.2		
I_{INB}	Enable pin B (V_{EN_B}) input current	$V_{EN_B} = 3.8\text{V}$			4.0	4.9	μA
		$V_{EN_B} = 1.8\text{V}$			1.8		
t_{SD}	Shutdown delay time	Delay from EN_A and $EN_B = \text{low}$ to reach shutdown current ($I_{DX} = 0.1 \times I_{DX, nom}$)		5	13	30	μs
T_{SD}	Thermal shutdown temperature	Shutdown, temp increasing			+165		$^\circ\text{C}$
		Reset, temp decreasing			+140		

(1) Average of all four I_{DX} outputs.

Table 1. Recommended (1% Tolerance) Set Resistor Values

R_{SET} (kΩ)	I_{SET} (μA)	I_{DX} (mA)⁽¹⁾
511	2.4	1.0
255	4.8	2.0
169	7.2	3.0
127	9.6	4.1
102	12.0	5.0
84.5	14.5	6.1
73.2	16.7	7.0
64.9	18.9	7.9
56.2	21.8	9.2
51.1	24.0	10.1
46.4	26.4	11.1
42.2	29.0	12.2
39.2	31.3	13.1
36.5	33.6	14.1
34.0	36.0	15.1
32.4	37.8	15.9
30.1	40.7	17.1
28.7	42.7	17.9
26.7	45.9	19.3
25.5	48.0	20.2
24.3	50.4	21.2
23.2	52.8	22.2
22.1	55.4	23.3
21.5	57.0	23.9
20.5	59.8	25.1

(1) $I_{DX} = (V_{SET}/R_{SET}) \times k$.

PIN ASSIGNMENTS

**YFF PACKAGE
9-BALL WCSP
(TOP VIEW)**

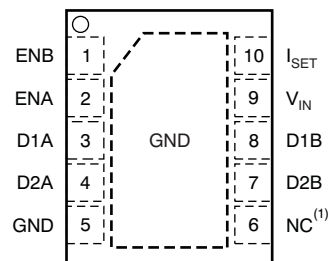
**DSK PACKAGE
2,5mm x 2,5mm SON-10
(TOP VIEW)**

NOTE (1): Not connected

TERMINAL FUNCTIONS

NAME	WCSP	SON	INPUT/ OUTPUT	DESCRIPTION
ENA	A3	2	I	Enable pin, Bank A. Driving this pin high turns on the current source to Bank A outputs. Driving this pin low turns off the current source to Bank A outputs. An applied PWM signal reduces the LED current (between 0mA and the maximum current set by I_{SET}) as a function of the duty cycle of the PWM signal. ENA and ENB can be tied together. ENA can be left OPEN or connected to GND if not used. See the Application Information section for more details.
D1A	B3	3	O	Diode source current output, Bank A. Connect to LED anode.
D2A	C3	4	O	Diode source current output, Bank A. Connect to LED anode.
ENB	A2	1	I	Enable pin, Bank B. Driving this pin high turns on the current source to Bank B outputs. Driving this pin low turns off the current source to Bank B outputs. An applied PWM signal reduces the LED current (between 0mA and the maximum current set by I_{SET}) as a function of the duty cycle of the PWM signal. ENA and ENB can be tied together. ENB can be left OPEN or connected to GND if not used. See the Application Information section for more details.
V_{IN}	B2	9	I	Supply Input
GND	C2	5, Pad	—	Ground
I_{SET}	A1	10	O	An optional resistor can be connected between this pin and GND to set the maximum current through the LEDs. If no resistor is connected, I_{SET} defaults to the internally-programmed value.
D1B	B1	8	O	Diode source current output, Bank B. Connect to LED anode.
D2B	C1	7	O	Diode source current output, Bank B. Connect to LED anode.
NC	—	6	—	Not connected.

FUNCTIONAL BLOCK DIAGRAM

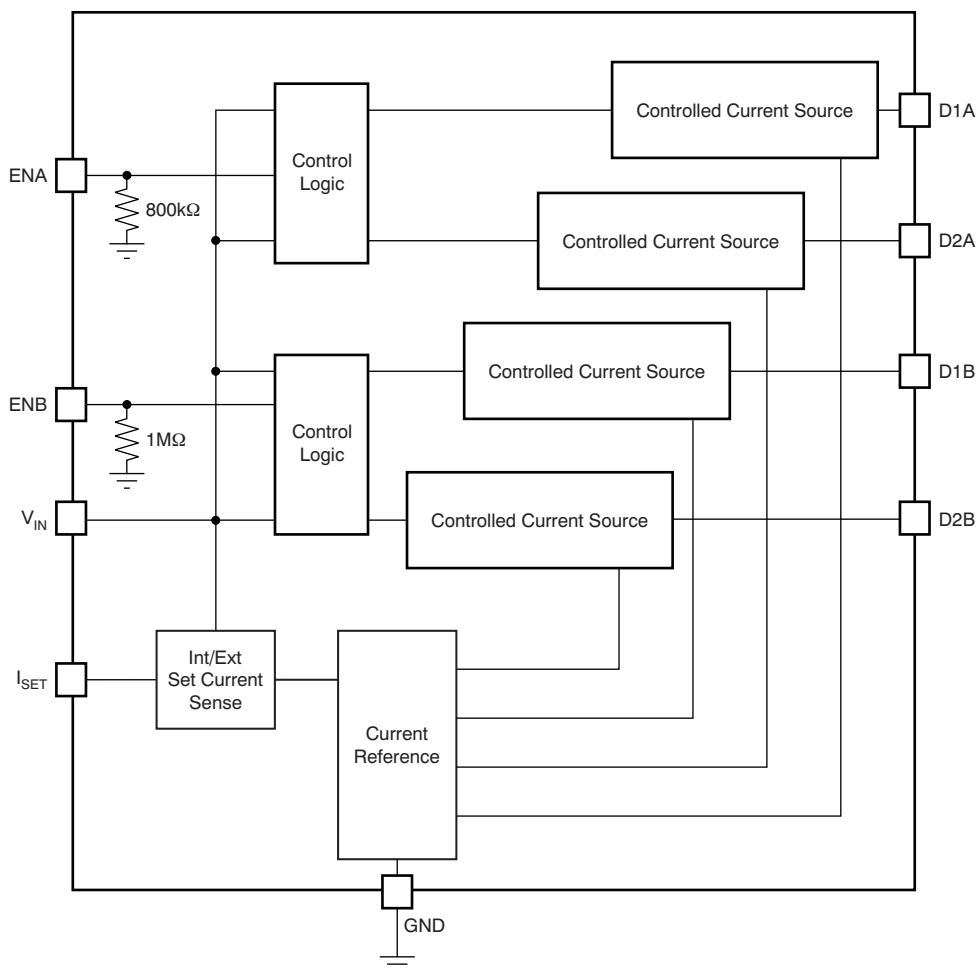

TYPICAL CHARACTERISTICS

Over operating junction temperature range ($T_J = -40^\circ\text{C}$ to $+85^\circ\text{C}$), $V_{IN} = 3.8\text{V}$, DxA and $DxB = 3.3\text{V}$, $R_{SET} = 32.4\text{k}\Omega$, and ENA and $ENB = \text{high}$, unless otherwise noted. Typical values are at $T_A = +25^\circ\text{C}$.

LED CURRENT vs DUTY CYCLE (f = 300Hz)

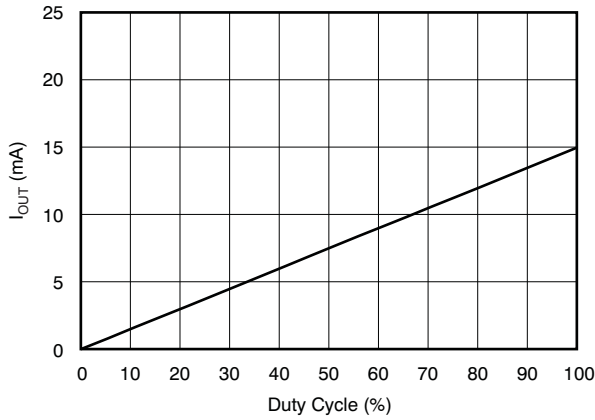

Figure 1.

LINE TRANSIENT (600mV Pulse)

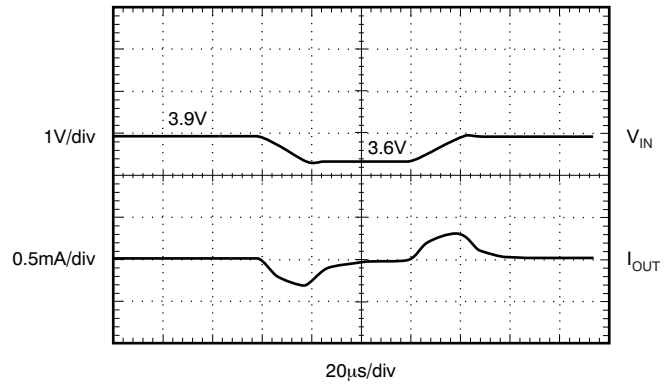

Figure 2.

LINE TRANSIENT (300mV Pulse)

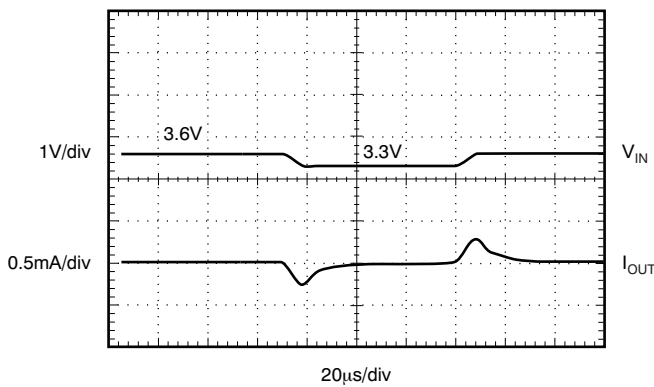

Figure 3.

DIMMING RESPONSE (Both Channels)

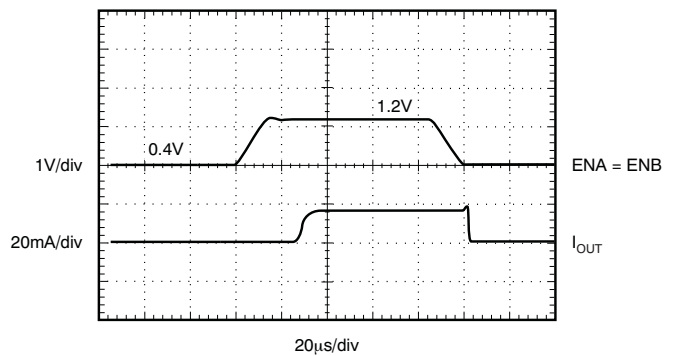

Figure 4.

DIMMING RESPONSE (Single Channel)

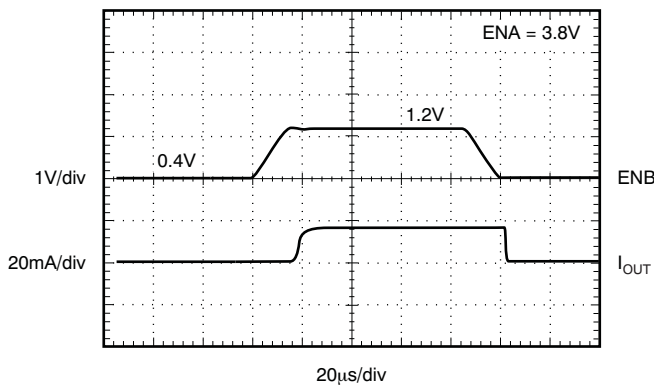

Figure 5.

OUTPUT CURRENT vs HEADROOM VOLTAGE

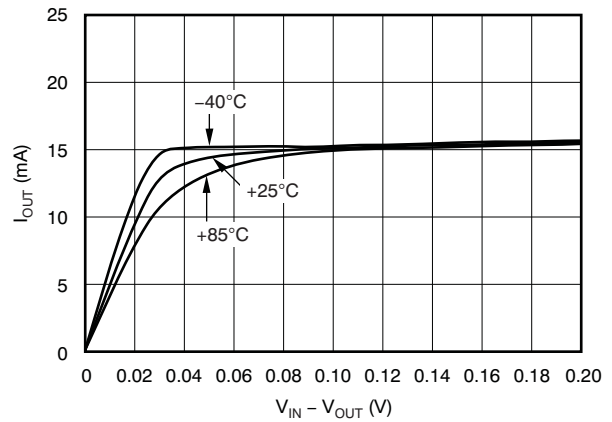

Figure 6.

TYPICAL CHARACTERISTICS (continued)

Over operating junction temperature range ($T_J = -40^\circ\text{C}$ to $+85^\circ\text{C}$), $V_{IN} = 3.8\text{V}$, DxA and $DxB = 3.3\text{V}$, $R_{SET} = 32.4\text{k}\Omega$, and EN_A and $EN_B = \text{high}$, unless otherwise noted. Typical values are at $T_A = +25^\circ\text{C}$.

OUTPUT CURRENT vs R_{SET}

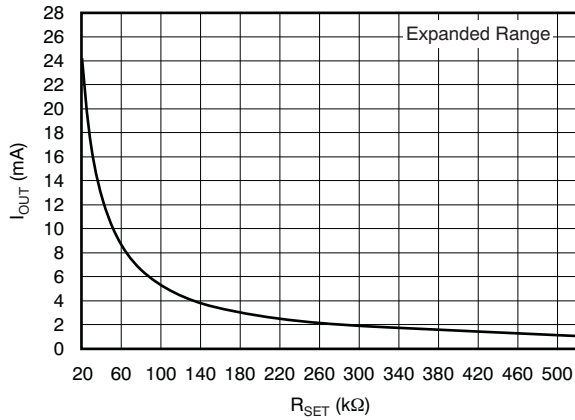

Figure 7.

OUTPUT CURRENT vs R_{SET}

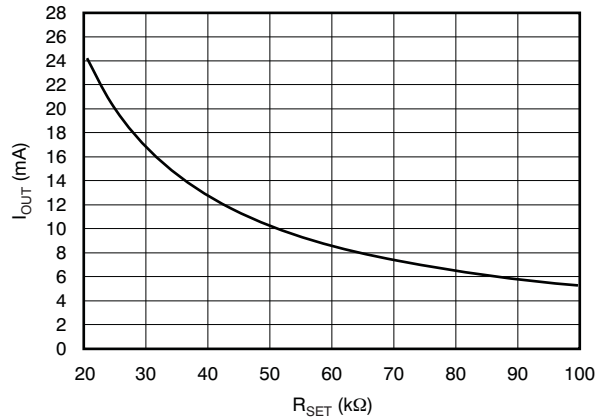

Figure 8.

GROUND CURRENT vs INPUT VOLTAGE

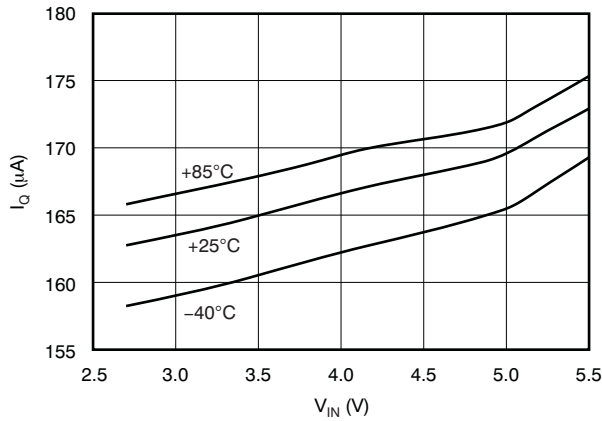

Figure 9.

TPS75105 OUTPUT CURRENT vs INPUT VOLTAGE
 $R_{SET} = \text{Open}$

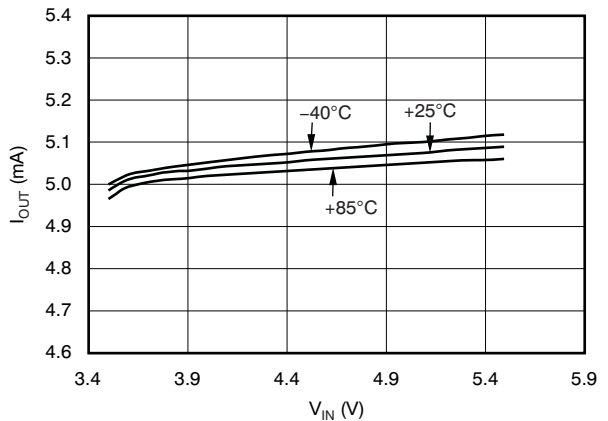

Figure 10.

TPS75105 OUTPUT CURRENT vs TEMPERATURE
 $R_{SET} = \text{Open}$

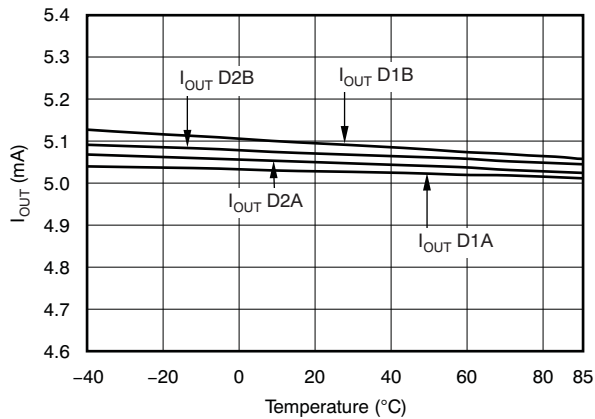

Figure 11.

OUTPUT CURRENT vs OUTPUT VOLTAGE

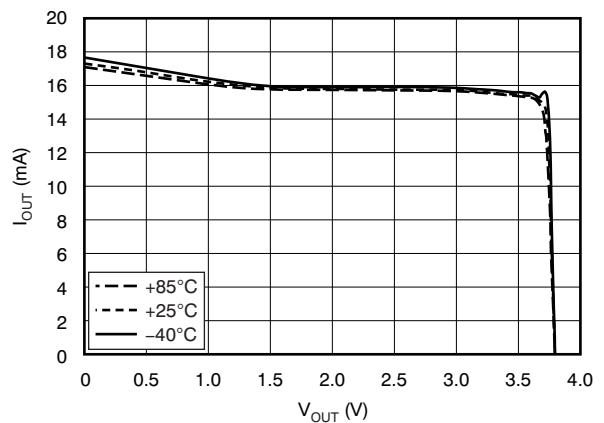

Figure 12.

APPLICATIONS INFORMATION

SETTING THE OUTPUT CURRENT LEVEL

The TPS7510x is a quad matched current source. Each of the four current source output levels is set by a single reference current. An internal voltage reference of 1.225V (nominal) in combination with a resistor sets the reference current level. This reference current is then mirrored onto each of the four outputs with a ratio of typically 420:1. The resistor required to set the LED current is calculated using [Equation 1](#):

$$R_{ISET} = \frac{K \times V_{ISET}}{I_{LED}}$$

where:

- K is the current ratio
 - V_{ISET} is the internal reference voltage
 - I_{LED} is the desired LED current
- (1)

For example, to set the LED current level to 10mA, a resistor value of 51.1k Ω is required. This value sets up a reference current of 23.9 μ A (1.22V/51.1k Ω). In turn, this reference current is mirrored to each output current source, resulting in an output current of 10mA (23.9 μ A \times 420).

The TPS7510x offers two methods for setting the output current levels. The LED current is set either by connecting a resistor (calculated using [Equation 1](#)) from the I_{SET} pin to GND, or leaving I_{SET} unconnected to employ the factory-programmed R_{SET} resistance. The internal programmed resistance is implemented using high-precision processing and yields a reference current accuracy of 0.5%, nominal. Accuracy using external resistors is subject to the tolerance of the external resistor and the accuracy of the internal reference voltage.

The TPS7510x automatically detects the presence of an external resistor by monitoring the current out of the I_{SET} pin. Current levels in excess of 3 μ A signify the presence of an external resistor and the device uses the external resistor to set the reference current. If the current from I_{SET} is less than 3 μ A, the device defaults to the preset internal reference set resistor. The TPS7510x is available with eight preset current levels, from 3mA to 10mA (per output) in 1mA increments. Solutions using the preset internal current level eliminate an external component, thereby increasing accuracy and reducing cost.

LIMITATIONS ON LED FORWARD VOLTAGES

The TPS7510x is a linear current source implementing LDO regulator building blocks. Therefore, there are some limitations to the forward (output) voltages that can be used while maintaining accurate operation. The first limitation is the maximum LED forward voltage. Because LDO technology is employed, there is the dropout voltage to consider. The TPS7510x is an ultra-low dropout device with typical dropouts in the range of 30mV at 5mA. Care must be taken in the design to ensure that the difference between the lowest possible input voltage (for example, battery cut-off) and the highest possible forward voltage yields at least 100mV of headroom. Headroom levels less than dropout decrease the accuracy of the current source (see [Figure 6](#)).

The other limitation to consider is the minimum output voltage required to yield accurate operation. The current source employs NMOS MOSFETs, and a minimum forward LED voltage of approximately 1.5V on the output is required to maintain highest accuracy. The TPS7510x is ideal for white LEDs and color LEDs with forward voltages greater than 1.5V. This range includes red LEDs that have typical forward voltages of 1.7V.

USE OF EXTERNAL CAPACITORS

The TPS7510x does not require the use of any external capacitors for stable operation. Nominal stray and/or power-supply decoupling capacitance on the input is adequate for stable operation. Capacitors are not recommended on the outputs because they are not needed for stability.

USE OF UNUSED OUTPUTS OR TYING OUTPUTS TOGETHER

Unused outputs may be left unconnected or tied to the V_{IN} supply. While open outputs are acceptable, tying unused outputs to the V_{IN} supply increases ESD protection. Connecting unused output to ground violates the minimum recommended output voltage, results in current levels that potentially exceed the set/preset LED current and should be avoided.

Connecting outputs in parallel is an acceptable way of increasing the amount of LED current drive. This configuration is a useful trick when the higher current level is a multiple of the preset value.

USE OF ENABLE PINS FOR PWM DIMMING

The TPS7510x divides control of the LED outputs into two banks of two current sources each. Each bank is controlled by the use of an independent, active-high enable pin (ENA and ENB). The enable pin can be used for standard ON/OFF operation of the current source, driven by standard logic levels from processor GPIO pins, for example. Drive EN high to turn on the bank of LEDs; drive EN low to turn off the bank of LEDs.

Another use of the enable pin is for LED dimming. LED brightness is a function of the current level being driven across the diode and the time that current is being driven through the diode. The perceived brightness of an LED can be changed by either varying the current level or, more effectively, by changing the time in which that current is present. When a PWM signal is input into the enable pin, the duty cycle (high or ON time) determines how long the fixed current is driven across the LEDs. Reducing or increasing that duration has the effect of dimming or brightening the LED, without having to employ the more complex method of varying the current level. This technique is particularly useful for reducing LED brightness in low ambient light conditions, where LED brightness is not required, thereby decreasing current consumption. The enable pins can also be used for LED blinking, varying blink rates based on system status.

Although providing many useful applications, PWM dimming does have a minimum duty cycle required to achieve the required current level. The recommended minimum on time of the TPS7510x is approximately 33 μ s. On times less than 33 μ s result in reductions in the output current by not allowing enough time for the output to reach the desired current level. Also, having both enables switching together, asynchronously, or having one enable on at all times, impacts the minimum recommended on time (see [Figure 4](#) and [Figure 5](#)). If one enable is already on, the speed at which the other channel turns on is faster than if both channels were turning on together or if the other channel is off. Therefore, connecting one enable on allows for approximately 10 μ s to 12 μ s shorter minimum on times of the switching enable channel.

Unused enable pins can be left unconnected or connected to ground to minimize current consumption. Connecting unused enable pins to ground increases ESD protection. If connected to V_{IN} , a small amount of current drains through the enable input (see the [Electrical Characteristics](#) table).

LOAD REGULATION

The TPS7510x is designed to provide very tight load regulation. In the case of a fixed current source, the output load change is a change in voltage. Tight load regulation means that output voltages (LED forward voltages) with large variations can be used without impacting the fixed current being sourced by the output or the output-to-output current matching. The permissible variation on the output not only allows for large variations in white LED forward voltages, but even permits the use of different color LEDs on different outputs with minimal effect on output current.

LINE REGULATION

The TPS7510x is also designed to provide very tight line regulation. This architecture allows for voltage transient events to occur on the power supply (battery) without impacting the fixed output current levels or the output to output current matching. A prime example of such a supply transient event is the occurrence of a transmit pulse on the radio of a mobile handset. These transient pulses can cause variations of 300mV and 600mV on the supply to the TPS7510x. The line regulation limitation is that the lower supply voltage level of the event does not cause the input to output voltage difference to drop below the dropout voltage range.

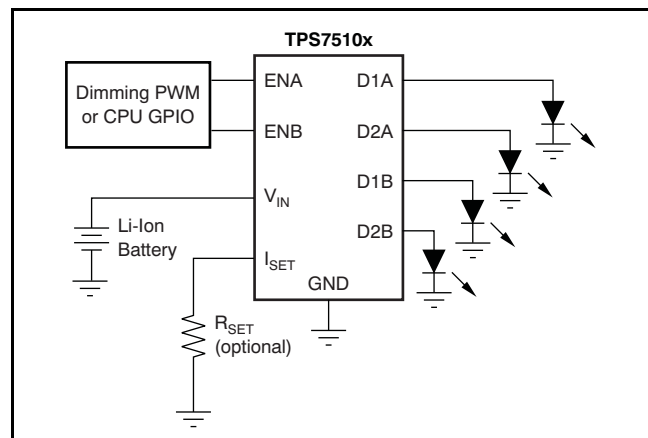

Figure 13. Typical Application Diagram

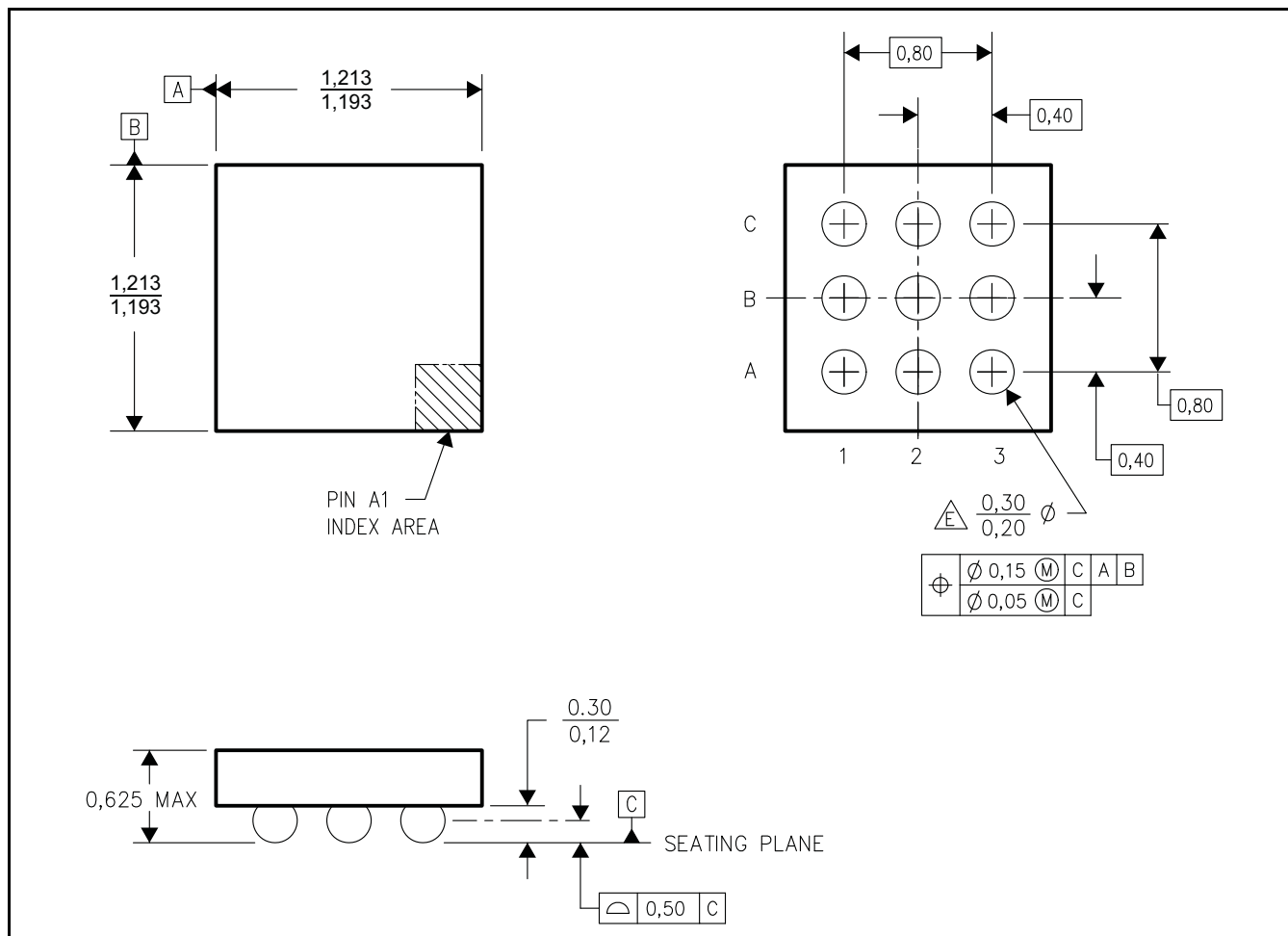

Figure 14. YFF Wafer Chip-Scale Package Dimensions (in mm)

REVISION HISTORY

NOTE: Page numbers for previous revisions may differ from page numbers in the current version.

Changes from Revision G (March, 2009) to Revision H	Page
• Added DSK package dissipation information to Dissipation Ratings table	2
• Revised ground current parameter, Electrical Characteristics; changed symbol from I_Q to I_{GND} ; added specifications for YFF and DSK packages	3
• Added YFF and DSK package specifications for current matching parameter, Electrical Characteristics	3
• Changed diode current accuracy parameter, Electrical Characteristics, to reflect YFF and DSK package specifications	3
• Deleted operating junction temperature range specification from Electrical Characteristics table to eliminate redundancy	3

PACKAGING INFORMATION

Orderable Device	Status (1)	Package Type	Package Drawing	Pins	Package Qty	Eco Plan (2)	Lead/Ball Finish	MSL Peak Temp (3)	Samples (Requires Login)
TPS75100YFFR	PREVIEW	DSBGA	YFF	9	3000	TBD	Call TI	Call TI	
TPS75100YFFT	PREVIEW	DSBGA	YFF	9	250	TBD	Call TI	Call TI	
TPS75103YFFR	ACTIVE	DSBGA	YFF	9	3000	Green (RoHS & no Sb/Br)	SNAGCU	Level-1-260C-UNLIM	
TPS75103YFFT	ACTIVE	DSBGA	YFF	9	250	Green (RoHS & no Sb/Br)	SNAGCU	Level-1-260C-UNLIM	
TPS75105DSKR	ACTIVE	SON	DSK	10	3000	Green (RoHS & no Sb/Br)	CU NIPDAU	Level-1-260C-UNLIM	
TPS75105DSKT	ACTIVE	SON	DSK	10	250	Green (RoHS & no Sb/Br)	CU NIPDAU	Level-1-260C-UNLIM	
TPS75105YFFR	ACTIVE	DSBGA	YFF	9	3000	Green (RoHS & no Sb/Br)	SNAGCU	Level-1-260C-UNLIM	
TPS75105YFFT	ACTIVE	DSBGA	YFF	9	250	Green (RoHS & no Sb/Br)	SNAGCU	Level-1-260C-UNLIM	

(1) The marketing status values are defined as follows:

ACTIVE: Product device recommended for new designs.

LIFEBUY: TI has announced that the device will be discontinued, and a lifetime-buy period is in effect.

NRND: Not recommended for new designs. Device is in production to support existing customers, but TI does not recommend using this part in a new design.

PREVIEW: Device has been announced but is not in production. Samples may or may not be available.

OBsolete: TI has discontinued the production of the device.

(2) Eco Plan - The planned eco-friendly classification: Pb-Free (RoHS), Pb-Free (RoHS Exempt), or Green (RoHS & no Sb/Br) - please check <http://www.ti.com/productcontent> for the latest availability information and additional product content details.

TBD: The Pb-Free/Green conversion plan has not been defined.

Pb-Free (RoHS): TI's terms "Lead-Free" or "Pb-Free" mean semiconductor products that are compatible with the current RoHS requirements for all 6 substances, including the requirement that lead not exceed 0.1% by weight in homogeneous materials. Where designed to be soldered at high temperatures, TI Pb-Free products are suitable for use in specified lead-free processes.

Pb-Free (RoHS Exempt): This component has a RoHS exemption for either 1) lead-based flip-chip solder bumps used between the die and package, or 2) lead-based die adhesive used between the die and leadframe. The component is otherwise considered Pb-Free (RoHS compatible) as defined above.

Green (RoHS & no Sb/Br): TI defines "Green" to mean Pb-Free (RoHS compatible), and free of Bromine (Br) and Antimony (Sb) based flame retardants (Br or Sb do not exceed 0.1% by weight in homogeneous material)

(3) MSL, Peak Temp. -- The Moisture Sensitivity Level rating according to the JEDEC industry standard classifications, and peak solder temperature.

Important Information and Disclaimer: The information provided on this page represents TI's knowledge and belief as of the date that it is provided. TI bases its knowledge and belief on information provided by third parties, and makes no representation or warranty as to the accuracy of such information. Efforts are underway to better integrate information from third parties. TI has taken and

continues to take reasonable steps to provide representative and accurate information but may not have conducted destructive testing or chemical analysis on incoming materials and chemicals. TI and TI suppliers consider certain information to be proprietary, and thus CAS numbers and other limited information may not be available for release.

In no event shall TI's liability arising out of such information exceed the total purchase price of the TI part(s) at issue in this document sold by TI to Customer on an annual basis.

TAPE AND REEL INFORMATION

QUADRANT ASSIGNMENTS FOR PIN 1 ORIENTATION IN TAPE

*All dimensions are nominal

Device	Package Type	Package Drawing	Pins	SPQ	Reel Diameter (mm)	Reel Width W1 (mm)	A0 (mm)	B0 (mm)	K0 (mm)	P1 (mm)	W (mm)	Pin1 Quadrant
TPS75103YFFR	DSBGA	YFF	9	3000	180.0	8.4	1.45	1.45	0.8	4.0	8.0	Q1
TPS75103YFFT	DSBGA	YFF	9	250	180.0	8.4	1.45	1.45	0.8	4.0	8.0	Q1
TPS75105DSKR	SON	DSK	10	3000	179.0	8.4	2.73	2.73	0.8	4.0	8.0	Q2
TPS75105DSKT	SON	DSK	10	250	179.0	8.4	2.73	2.73	0.8	4.0	8.0	Q2
TPS75105YFFR	DSBGA	YFF	9	3000	180.0	8.4	1.45	1.45	0.8	4.0	8.0	Q1
TPS75105YFFT	DSBGA	YFF	9	250	180.0	8.4	1.45	1.45	0.8	4.0	8.0	Q1

TAPE AND REEL BOX DIMENSIONS

*All dimensions are nominal

Device	Package Type	Package Drawing	Pins	SPQ	Length (mm)	Width (mm)	Height (mm)
TPS75103YFFR	DSBGA	YFF	9	3000	210.0	185.0	35.0
TPS75103YFFT	DSBGA	YFF	9	250	210.0	185.0	35.0
TPS75105DSKR	SON	DSK	10	3000	203.0	203.0	35.0
TPS75105DSKT	SON	DSK	10	250	203.0	203.0	35.0
TPS75105YFFR	DSBGA	YFF	9	3000	210.0	185.0	35.0
TPS75105YFFT	DSBGA	YFF	9	250	210.0	185.0	35.0

DSK (S-PDSO-N10)

PLASTIC QUAD FLATPACK

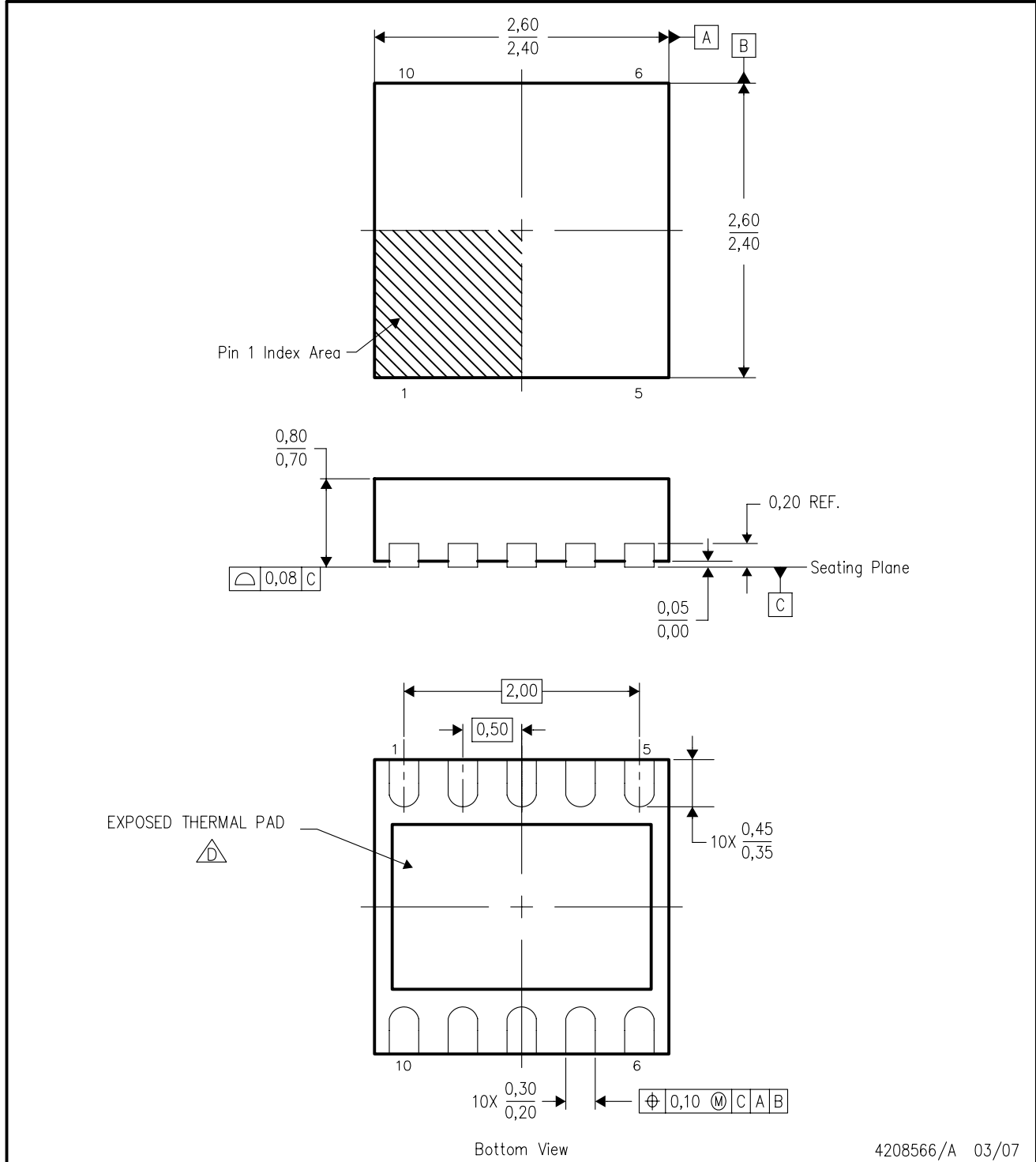

4208566/A 03/07

- NOTES:
- A. All linear dimensions are in millimeters. Dimensioning and tolerancing per ASME Y14.5M-1994.
 - B. This drawing is subject to change without notice.
 - C. Small Outline No-Lead (SON) package configuration.
 -  D. The package thermal pad must be soldered to the board for thermal and mechanical performance. See the Product Data Sheet for details regarding the exposed thermal pad dimensions.

THERMAL PAD MECHANICAL DATA

DSK (R-PWSON-N10)

PLASTIC SMALL OUTLINE NO-LEAD

THERMAL INFORMATION

This package incorporates an exposed thermal pad that is designed to be attached directly to an external heatsink. The thermal pad must be soldered directly to the printed circuit board (PCB). After soldering, the PCB can be used as a heatsink. In addition, through the use of thermal vias, the thermal pad can be attached directly to the appropriate copper plane shown in the electrical schematic for the device, or alternatively, can be attached to a special heatsink structure designed into the PCB. This design optimizes the heat transfer from the integrated circuit (IC).

For information on the Quad Flatpack No-Lead (QFN) package and its advantages, refer to Application Report, QFN/SON PCB Attachment, Texas Instruments Literature No. SLUA271. This document is available at www.ti.com.

The exposed thermal pad dimensions for this package are shown in the following illustration.

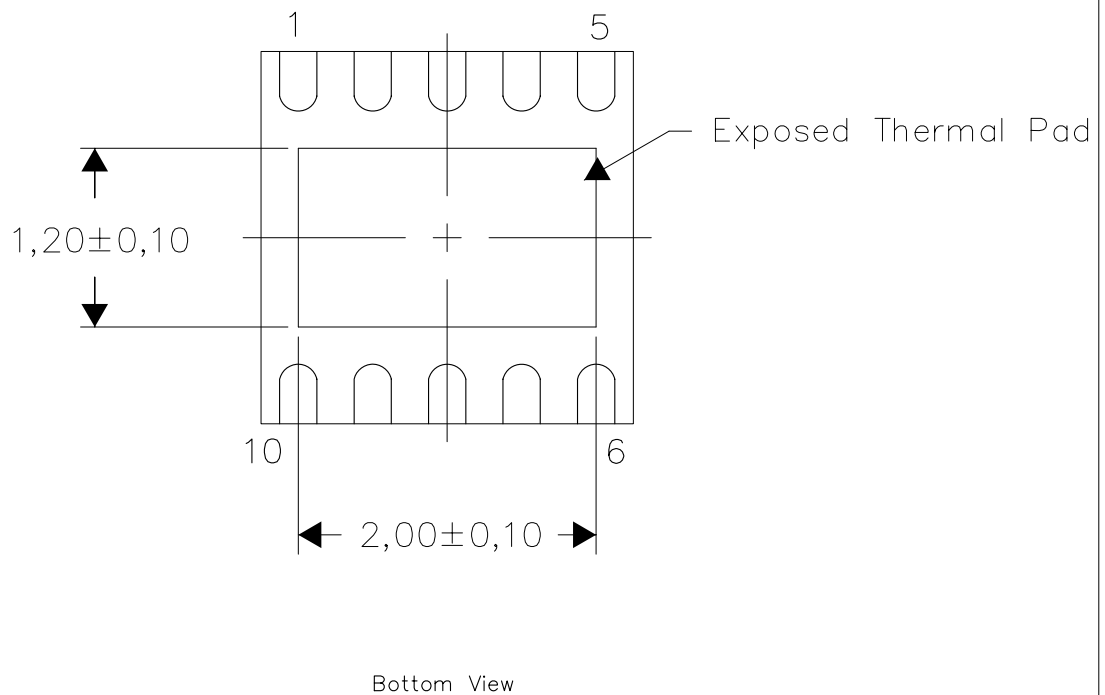

Exposed Thermal Pad Dimensions

4208579-2/D 10/10

NOTE: A. All linear dimensions are in millimeters

DSK (R-PWSON-N10)

PLASTIC SMALL OUTLINE NO-LEAD

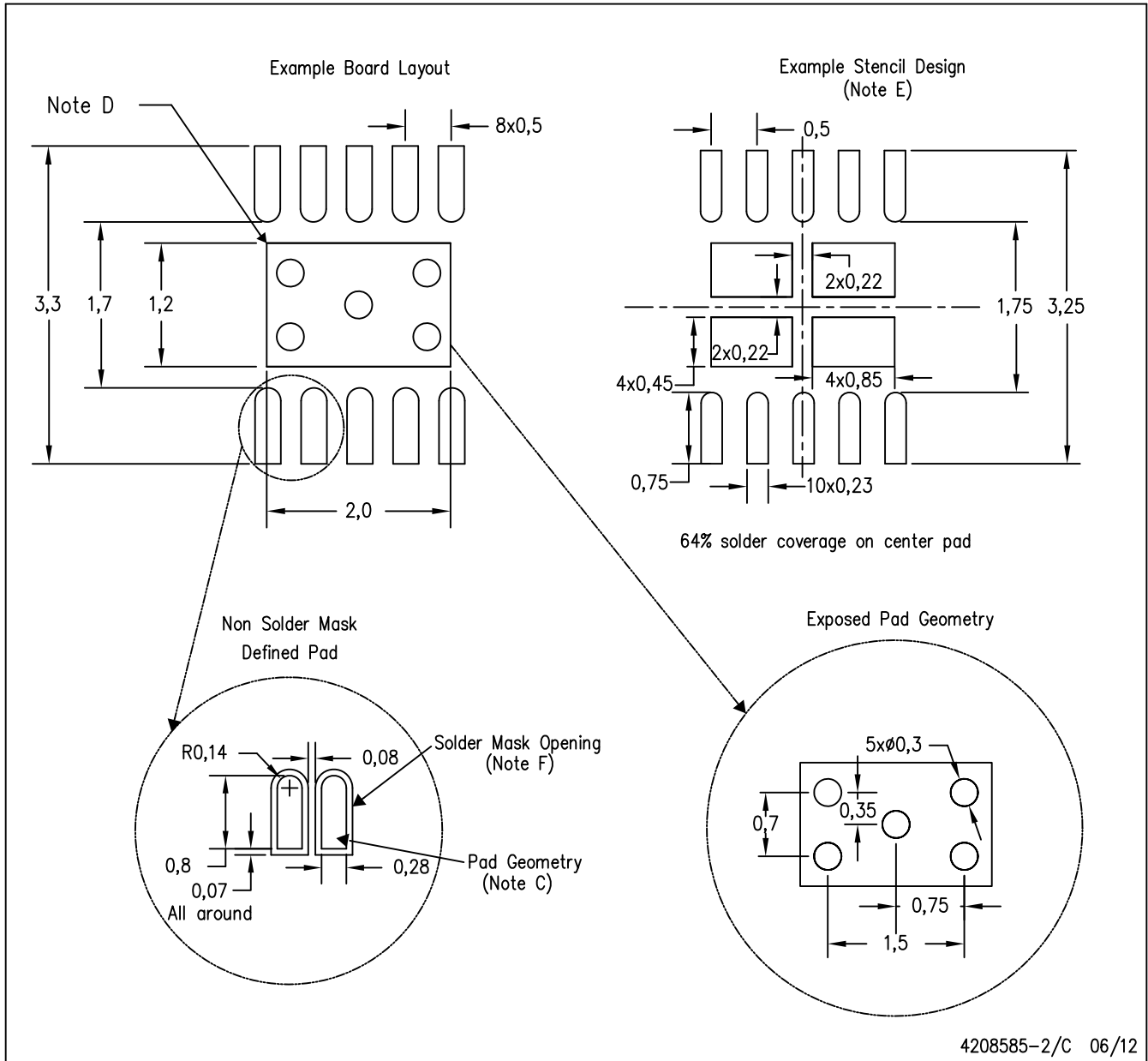

- NOTES:
- All linear dimensions are in millimeters.
 - This drawing is subject to change without notice.
 - Publication IPC-SM-782 is recommended for alternate designs.
 - This package is designed to be soldered to a thermal pad on the board. Refer to Application Note, Quad Flat-Pack Packages, Texas Instruments Literature No. SLUA271, and also the Product Data Sheets for specific thermal information, via requirements, and recommended board layout. These documents are available at www.ti.com <<http://www.ti.com>>.
 - Laser cutting apertures with trapezoidal walls and also rounding corners will offer better paste release. Customers should contact their board assembly site for stencil design recommendations. Refer to IPC 7525 for stencil design considerations.
 - Customers should contact their board fabrication site for minimum solder mask web tolerances between signal pads.

MECHANICAL DATA

YFF (S-XBGA-N9)

DIE-SIZE BALL GRID ARRAY

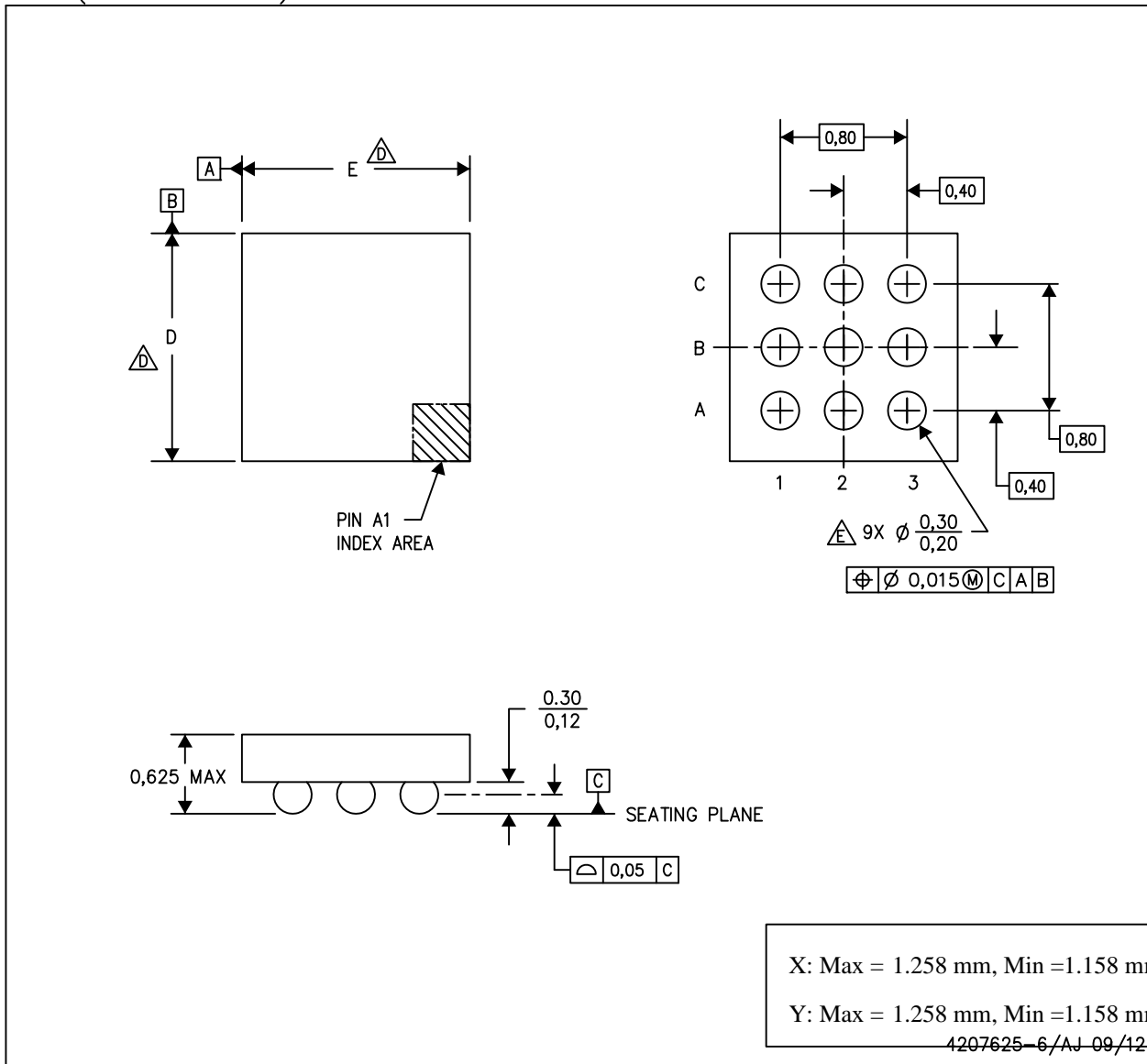

- NOTES:
- All linear dimensions are in millimeters. Dimensioning and tolerancing per ASME Y14.5M-1994.
 - This drawing is subject to change without notice.
 - NanoFree™ package configuration.
 - The package size (Dimension D and E) of a particular device is specified in the device Product Data Sheet version of this drawing, in case it cannot be found in the product data sheet please contact a local TI representative.
 - Reference Product Data Sheet for array population.
3 x 3 matrix pattern is shown for illustration only.
 - This package contains Pb-free balls.

NanoFree is a trademark of Texas Instruments

IMPORTANT NOTICE

Texas Instruments Incorporated and its subsidiaries (TI) reserve the right to make corrections, enhancements, improvements and other changes to its semiconductor products and services per JESD46, latest issue, and to discontinue any product or service per JESD48, latest issue. Buyers should obtain the latest relevant information before placing orders and should verify that such information is current and complete. All semiconductor products (also referred to herein as "components") are sold subject to TI's terms and conditions of sale supplied at the time of order acknowledgment.

TI warrants performance of its components to the specifications applicable at the time of sale, in accordance with the warranty in TI's terms and conditions of sale of semiconductor products. Testing and other quality control techniques are used to the extent TI deems necessary to support this warranty. Except where mandated by applicable law, testing of all parameters of each component is not necessarily performed.

TI assumes no liability for applications assistance or the design of Buyers' products. Buyers are responsible for their products and applications using TI components. To minimize the risks associated with Buyers' products and applications, Buyers should provide adequate design and operating safeguards.

TI does not warrant or represent that any license, either express or implied, is granted under any patent right, copyright, mask work right, or other intellectual property right relating to any combination, machine, or process in which TI components or services are used. Information published by TI regarding third-party products or services does not constitute a license to use such products or services or a warranty or endorsement thereof. Use of such information may require a license from a third party under the patents or other intellectual property of the third party, or a license from TI under the patents or other intellectual property of TI.

Reproduction of significant portions of TI information in TI data books or data sheets is permissible only if reproduction is without alteration and is accompanied by all associated warranties, conditions, limitations, and notices. TI is not responsible or liable for such altered documentation. Information of third parties may be subject to additional restrictions.

Resale of TI components or services with statements different from or beyond the parameters stated by TI for that component or service voids all express and any implied warranties for the associated TI component or service and is an unfair and deceptive business practice. TI is not responsible or liable for any such statements.

Buyer acknowledges and agrees that it is solely responsible for compliance with all legal, regulatory and safety-related requirements concerning its products, and any use of TI components in its applications, notwithstanding any applications-related information or support that may be provided by TI. Buyer represents and agrees that it has all the necessary expertise to create and implement safeguards which anticipate dangerous consequences of failures, monitor failures and their consequences, lessen the likelihood of failures that might cause harm and take appropriate remedial actions. Buyer will fully indemnify TI and its representatives against any damages arising out of the use of any TI components in safety-critical applications.

In some cases, TI components may be promoted specifically to facilitate safety-related applications. With such components, TI's goal is to help enable customers to design and create their own end-product solutions that meet applicable functional safety standards and requirements. Nonetheless, such components are subject to these terms.

No TI components are authorized for use in FDA Class III (or similar life-critical medical equipment) unless authorized officers of the parties have executed a special agreement specifically governing such use.

Only those TI components which TI has specifically designated as military grade or "enhanced plastic" are designed and intended for use in military/aerospace applications or environments. Buyer acknowledges and agrees that any military or aerospace use of TI components which have **not** been so designated is solely at the Buyer's risk, and that Buyer is solely responsible for compliance with all legal and regulatory requirements in connection with such use.

TI has specifically designated certain components which meet ISO/TS16949 requirements, mainly for automotive use. Components which have not been so designated are neither designed nor intended for automotive use; and TI will not be responsible for any failure of such components to meet such requirements.

Products

Audio	www.ti.com/audio
Amplifiers	amplifier.ti.com
Data Converters	dataconverter.ti.com
DLP® Products	www.dlp.com
DSP	dsp.ti.com
Clocks and Timers	www.ti.com/clocks
Interface	interface.ti.com
Logic	logic.ti.com
Power Mgmt	power.ti.com
Microcontrollers	microcontroller.ti.com
RFID	www.ti-rfid.com
OMAP Applications Processors	www.ti.com/omap
Wireless Connectivity	www.ti.com/wirelessconnectivity

Applications

Automotive and Transportation	www.ti.com/automotive
Communications and Telecom	www.ti.com/communications
Computers and Peripherals	www.ti.com/computers
Consumer Electronics	www.ti.com/consumer-apps
Energy and Lighting	www.ti.com/energy
Industrial	www.ti.com/industrial
Medical	www.ti.com/medical
Security	www.ti.com/security
Space, Avionics and Defense	www.ti.com/space-avionics-defense
Video and Imaging	www.ti.com/video

TI E2E Community

e2e.ti.com